

改訂図  
NO. 2  
★印記号は改訂内容

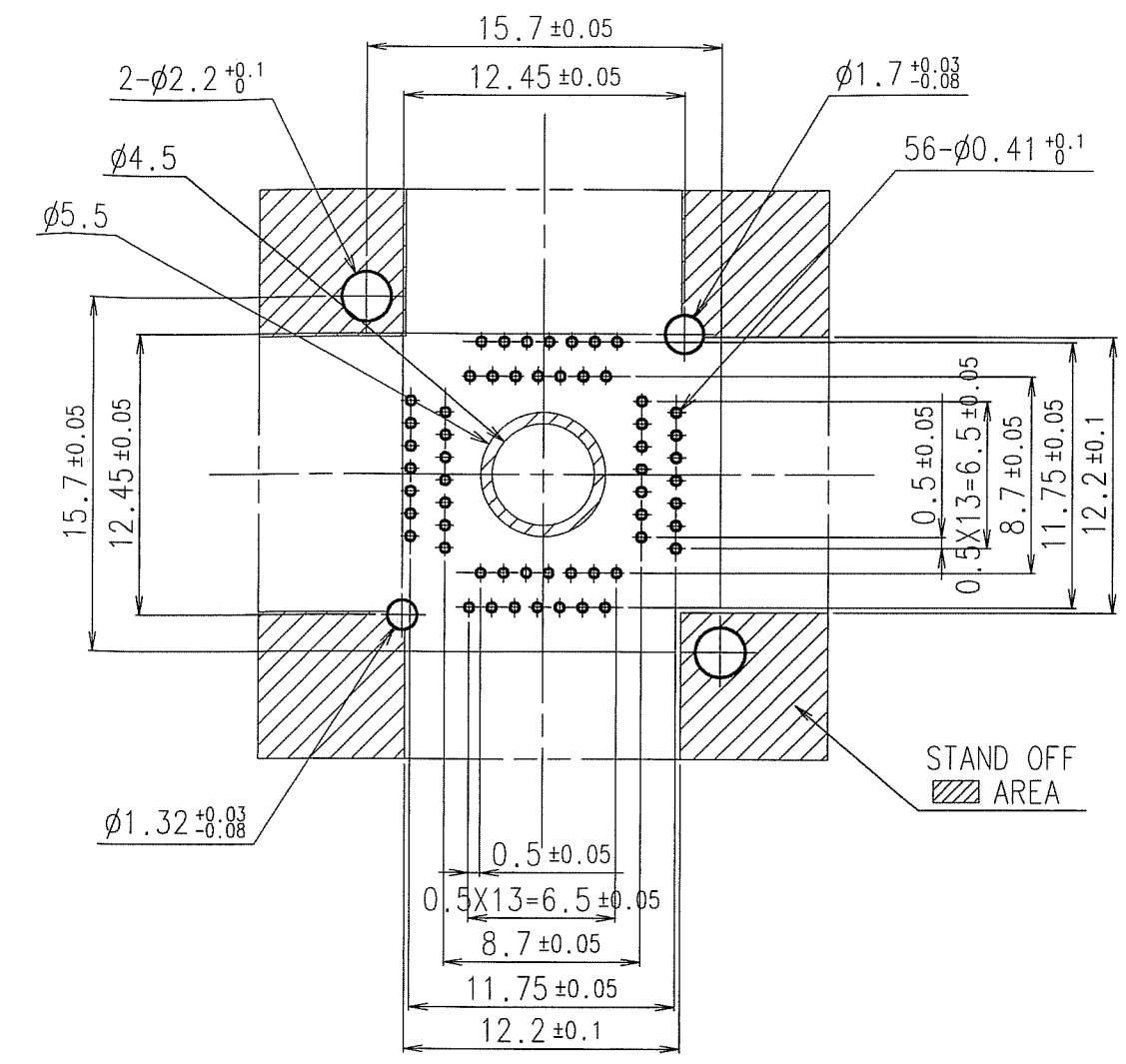
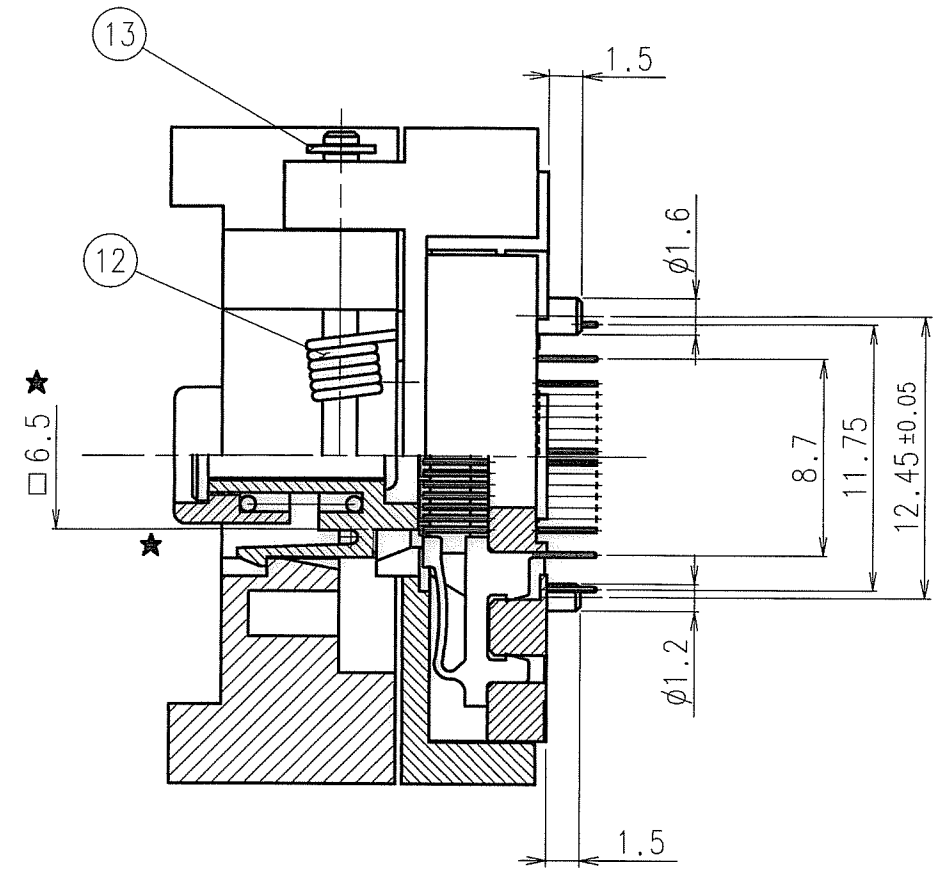
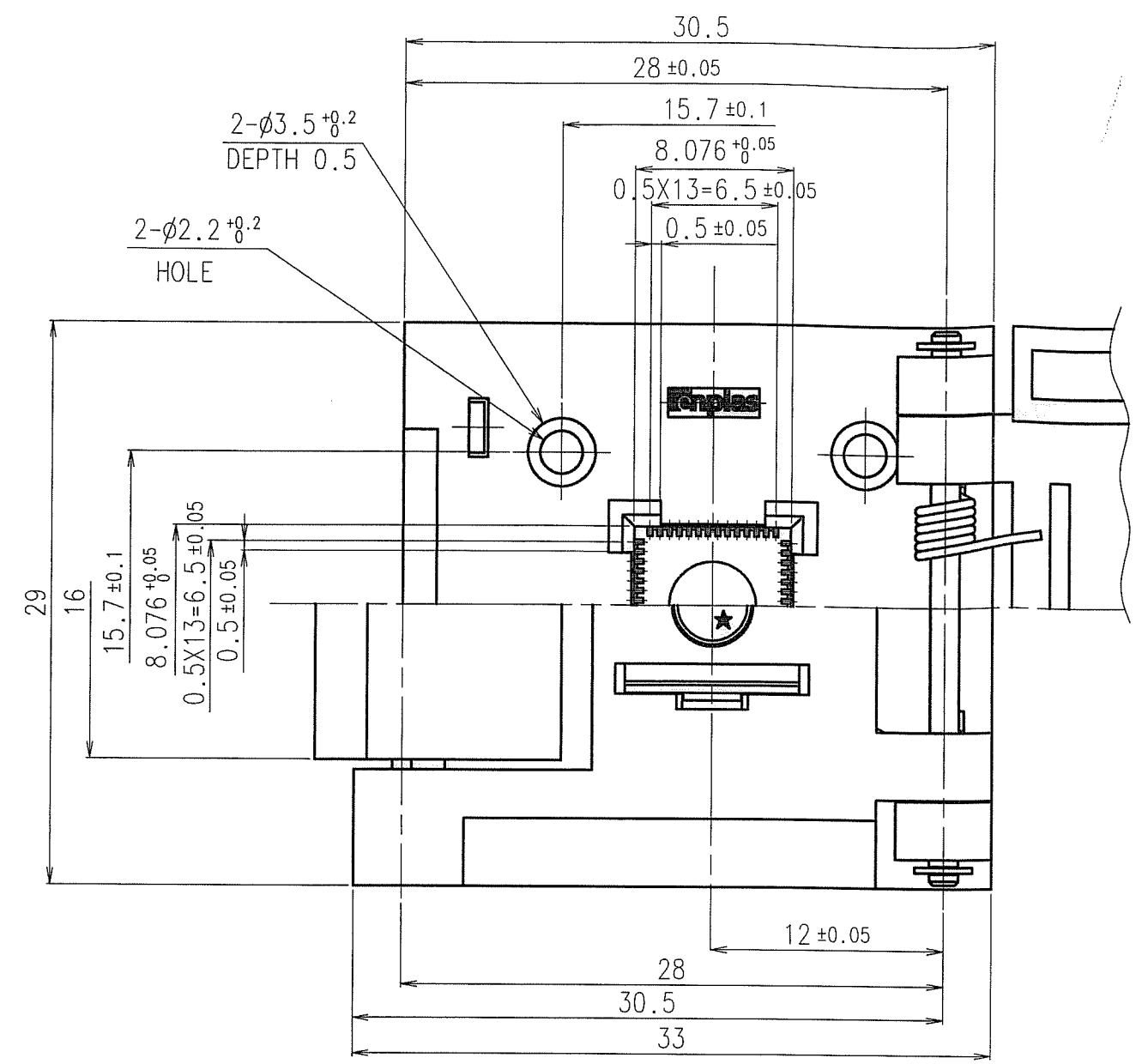

PCB PATTERN (TOP VIEW)  
(S=3:1)

NOTES

- 1) MARK PIN COUNT WITH HEAT RESISTANT WHITE INK.
- 2) Under the any humidity involved testing, the socket MUST be fixed on the BIB with provided screws.

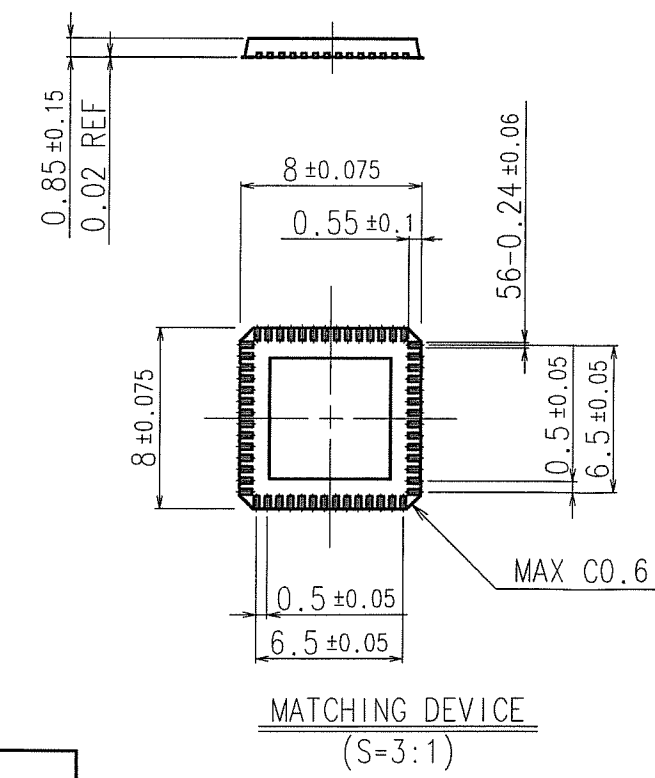
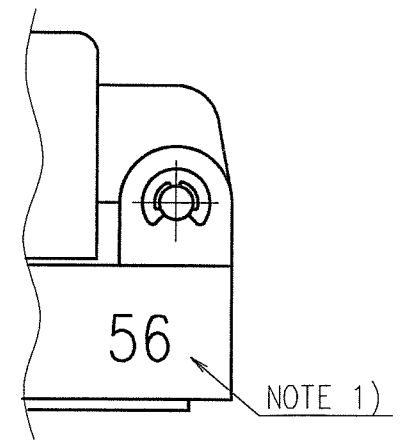

ESP CONFIDENTIAL

SPECIFICATION 仕様	
CONTACT RESISTANCE 接触抵抗	50mΩ or less at 10mA (INITIAL)
DIELECTRIC WITHSTANDING VOLTAGE 耐電圧	500 V.A.C for 1 minute
INSULATION RESISTANCE 絶縁抵抗	1000MΩ or more at 500V.D.C
OPERATING TEMPERATURE 使用温度	-65℃~150℃
RETENTION FORCE 端子抜け強度	0.5kg for 1 minute
INSERTION 寿命	10000 cycle(MECHANICAL)

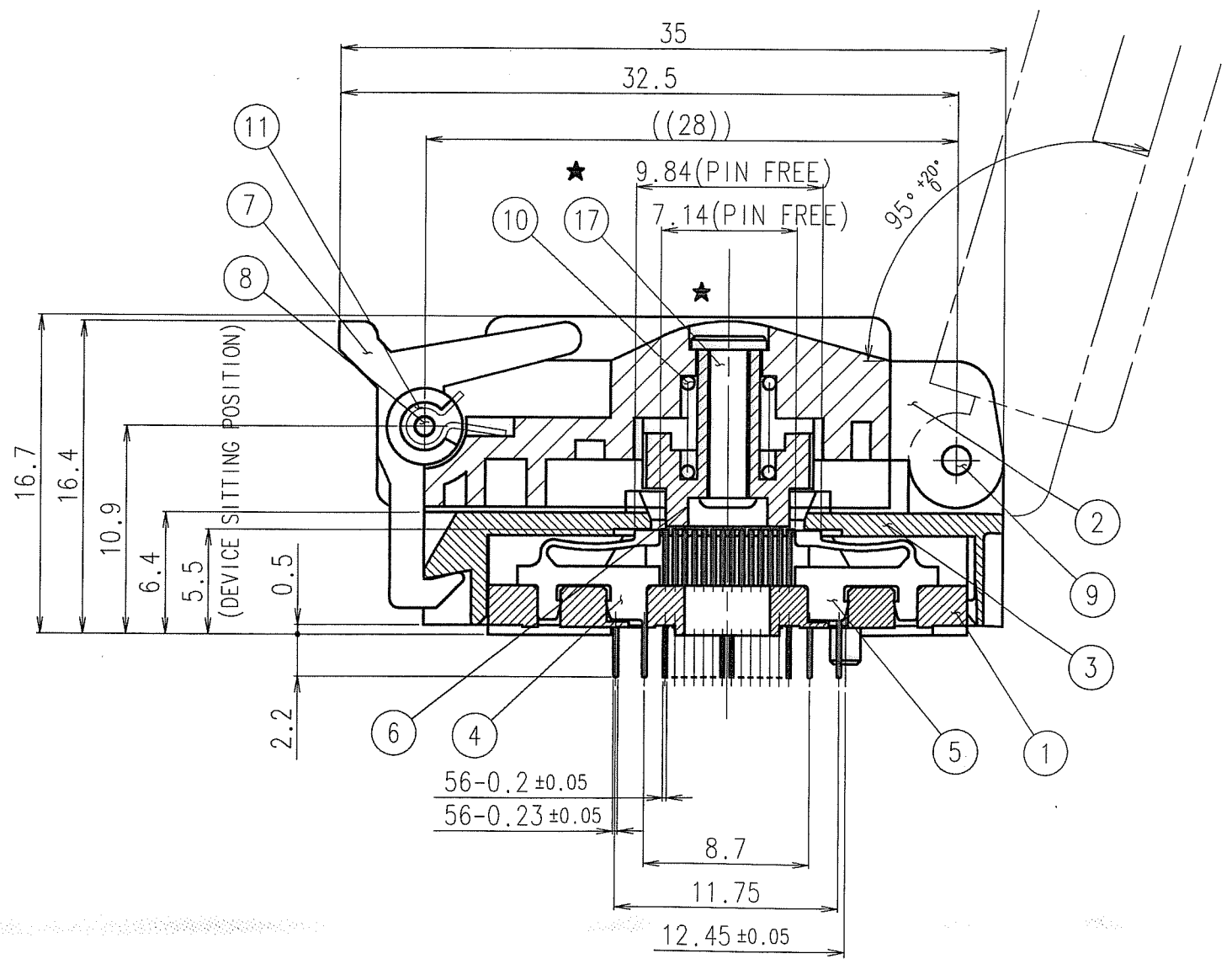

Part No.	Customer's Part No.	DWG. No.	Part Name	Material	Quantity	Remarks
★ 17	OQN-64-0.5-01-10	55-111-952-01	RIVET	SUS	1	
16	COTS	55-113-131-01	HEX. THIN NUT M2	SUS	2	SHIP WITH SOCKETS
15	COTS	55-113-111-01	SPRING LOCK WASHER 2.0	SUS	2	SHIP WITH SOCKETS
14	COTS	55-113-009-01	PAN HEAD SCREW M2XL10	SUS	2	SHIP WITH SOCKETS
13	COTS	55-113-002-01	E-RING(φ1.2)	SUS	2	
12	FP-28-1.27-09-003	55-112-035-01	COIL SPRING	SUS	1	FOR COVER
11	FPQ-64-1.0-01-004	55-112-007-01	COIL SPRING	SUS	1	FOR STOPPER
★ 10	QFN-68-0.5-01-11	55-112-808-01	COIL SPRING	SUS	1	FOR PUSHER
9	QFN-68-0.5-01-10	55-111-834-01	SHAFT	SUS	1	FOR COVER
8	QFN-68-0.5-01-09	55-111-833-01	SHAFT	SUS	1	FOR STOPPER
7	FPQ-64-1.0-01-003	55-299-043-01	STOPPER	PPS	1	
★ 6	QFN-64-0.5-001-05	58-290-443-01	PUSHER	PES	1	
5	QFN-68-0.5-01-08	56-110-743-01	FNAO CONTACT	BeCu	28	
4	QFN-68-0.5-01-07	56-110-742-01	FMZO CONTACT	BeCu	28	
3	QFN-56-0.5-01-04	56-290-891-01	GUIDE	PES	1	
2	QFN-68-0.5-01-05	56-290-835-01	COVER	PES	1	
1	QFN-56-0.5-01-01	56-290-870-01	BODY	PES	1	

SYMBOL	CUSTOMER'S PART NO.	DWG. NO.	NAME	MAT'L	Q'TY	REMARKS
△			機種 USED FOR	顧客品番 CUSTOMER'S PART NO.	一般公差 GENERAL TOLERANCES	±0.3, ±10°
△			承認者 APPROVED BY	品名 NAME	尺規 SCALE	3:1
△			検査者 CHECKED BY	QFN-56B-0.5-01-00	REV. NO.	C
△			設計者 DESIGNED BY	IC SOCKET		
△			製図者 DRAWN BY			
△			承認者 SIGN			
△	07.11.19	改訂図No.2発行(改訂箇所は★印8箇所)	H.S Y.M	製図者 A.MORISHITA	図番 DRAWING NO.	55-037-030-01 1/1
△		訂正年月日 DATE	承認者 SIGN	作成年月日 ISSUED ON		2003/12/22

c-02-00  
A2-A-SP

L	
K	
J	
I	
H	
G	
F	
E	
D	
C	
B	
A	